

GNL-3004xx (Φ 3mm ROUND TYPE) Ultra Brightness

ABSOLUTE MAXIMUM RATING:(Ta=25°C)

Parameter			Unit
DC Forward Current	30		mA
Reverse Voltage	5		V
Reverse Current (Vr=5V)	10		μA
Peak Forward Current ,tw ,=1 msec Duty ,=1/20	150		mA
Operation Temperature	-40	+80	°C
Storage Temperature	-40	+100	°C
Solder Dip (5 seconds,1.6mm from body) Temperature	300	±5	°C

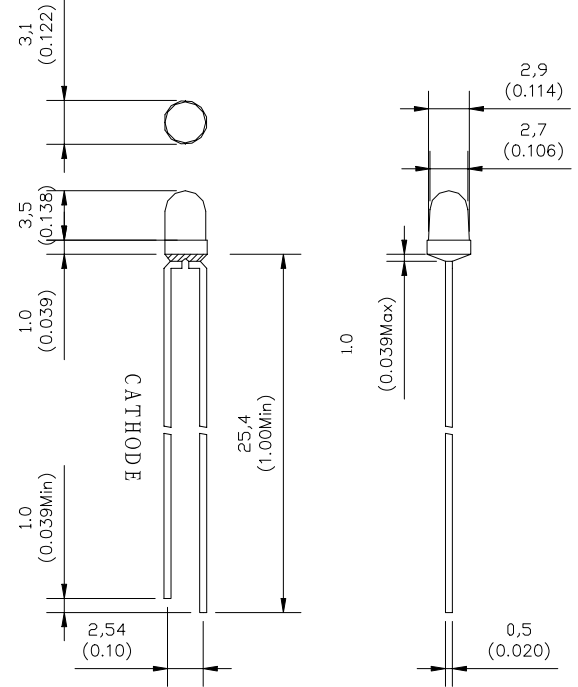

Feature:

- 1.Small flange without stand-off
- 2.Long life-solid state reliability
- 3.Long lead length(25.4mm)
- 4.Versatile mounting on P.C. board or panel

Description:

- 1.The shape of this series is round
- 2.General application is for indication,illumination,etc.
- 3.These LED lamps are available with a choice of defferent colors,light intensities,epoxy colors,etc.

Part Number	EMITTED COLOR		Lens Color	Peak Wavelength (nm)	Vf (v) Typ.	IV (If=20mA) mcd		View Angle 2 θ 1/2
						Min.	Typ.	
GNL-3004SRD	GaAlAs	Super Red	Red Diffused	660	1.9	70	100	60°
GNL-3004SRT	GaAlAs	Super Red	Red Transparent	660	1.9	100	200	25°
GNL-3004SRC	GaAlAs	Super Red	Water Clear	660	1.9	100	200	25°
GNL-3004LRC	GaAlAs	Super Red	Water Clear	660	1.9	200	300	25°
GNL-3004URC	GaAlAs	Super Red	Water Clear	660	1.9	400	500	25°
GNL-3004UEC	AlGaInP	Super Orange	Water Clear	625	2.0	900	1200	25°
GNL-3004UGC	AlGaInP	Yellow Green	Water Clear	572	2.0	400	500	25°
GNL-3004UYC	AlGaInP	Super Yellow	Water Clear	585	2.0	800	1000	25°
GNL-3004BC	InGaN	Super Blue	Water Clear	470	3.5	1200	1700	25°
GNL-3004UBC	InGaN	Ultra Super Blue	Water Clear	470	3.5	2500	2800	25°
GNL-3004BGC	InGaN	Super Bluish Green	Water Clear	505	3.5	5000	6000	35°
GNL-3004PGC	InGaN	Super Pure Green	Water Clear	525	3.5	6000	7500	25°
GNL-3004VC	InGaN	Ultra Super Violet	Water Clear	400	3.5	150	300	25°
GNL-3004WC	InGaN	Super White	Water Clear	5500K-7500K	3.5	4000	5000	25°
GNL-3004UWC	InGaN	Super White	Water Clear	5500k-7500k	3.5	4500	5500	25°